

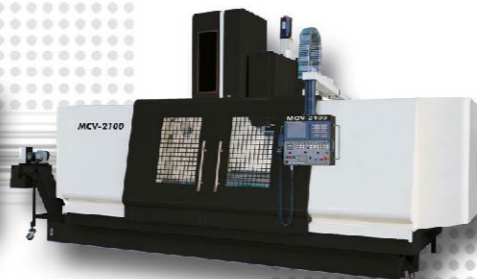

MCV-720
Vertical
Machining Center



DMV-800
Traveling Column
Vertical Machining
Center



MCV-2100
Vertical Machining
Center



MCH-630
Horizontal
Machining Center



MCH- 500A/800A



DAH LIH MACHINERY INDUSTRY CO., LTD.

No. 3, Kung-Yeh Lane, Fengcheng Road, Nanshih Village,
Wufeng District, Taichung City, 41357, Taiwan.

TEL:886-4-23334567 FAX:886-4-23307567

E-mail:export.sale@dahliah.com.tw Http://www.dahliah.com.tw



022-D2-00-008

HORIZONTAL MACHINING CENTERS

DAHLH

HORIZONTAL MACHINING CENTER

High-precision, highly-efficient machines lead in the coming age. Greeting the new era with varied performances.

Column: An assisting pneumatic system is employed in Z axis slideways to reduce friction of column feed by semi-floating way. This can make column movement smooth without "sticking-stiff". This not only increases accuracy, but also reduces the wear of Turcite-B of slideways.

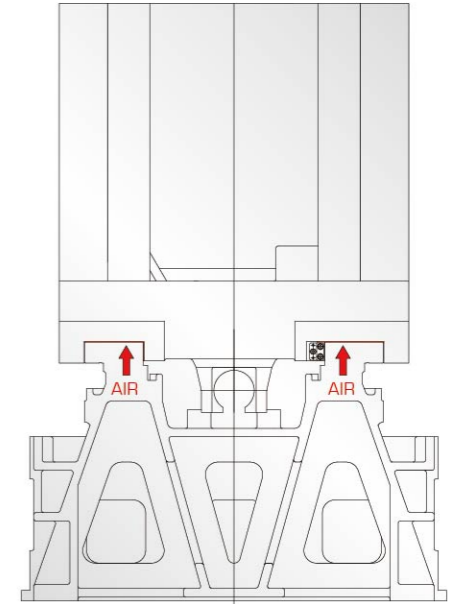

MCH-500A/800A



FEATURES AND CONSTRUCTION

AUTO PALLET CHANGER (A.P.C)

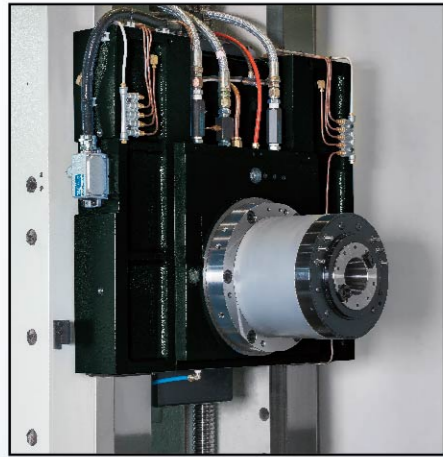

Spindle: Direct gear drive is employed for spindle with auto gear change. Full power output can be obtained from merely 302 rpm. Spindle and transmission gears are equipped with a forced cooling system to reduce heat and ensure accuracy. The headstock is mounted on the sliding surface of the column with 8-faces wrap-around enhancing rigidity and allowing heavy duty cutting. Headstock and column are symmetrically construction designed, which minimizes thermal deformation.

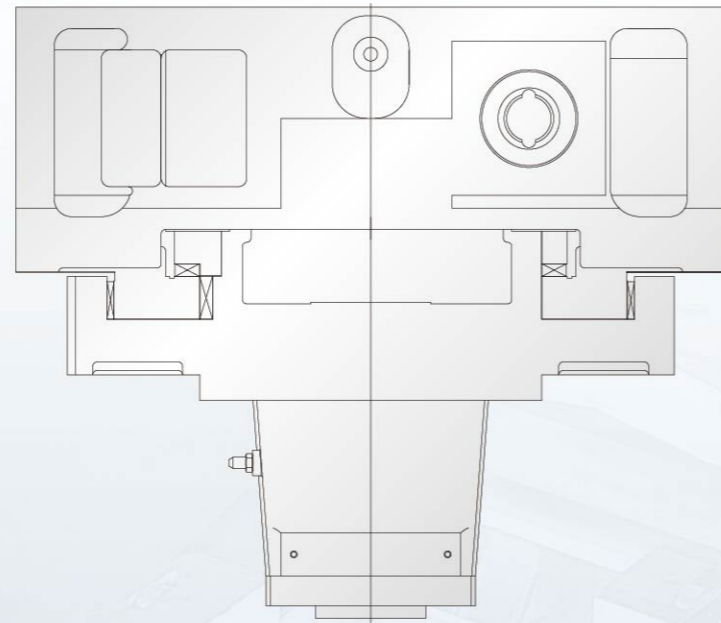

Shuttle-type designed to save space. A paddle for pallet rotation is available to make the loading/unloading workpieces convenient. A hydraulic-driven shuttle arm is used for pallet changing to ensure excellent reliability of A.P.C. movement.

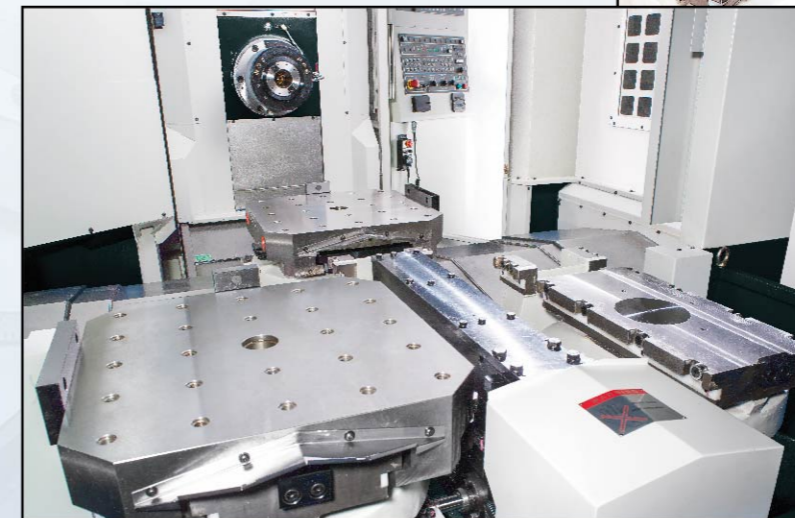
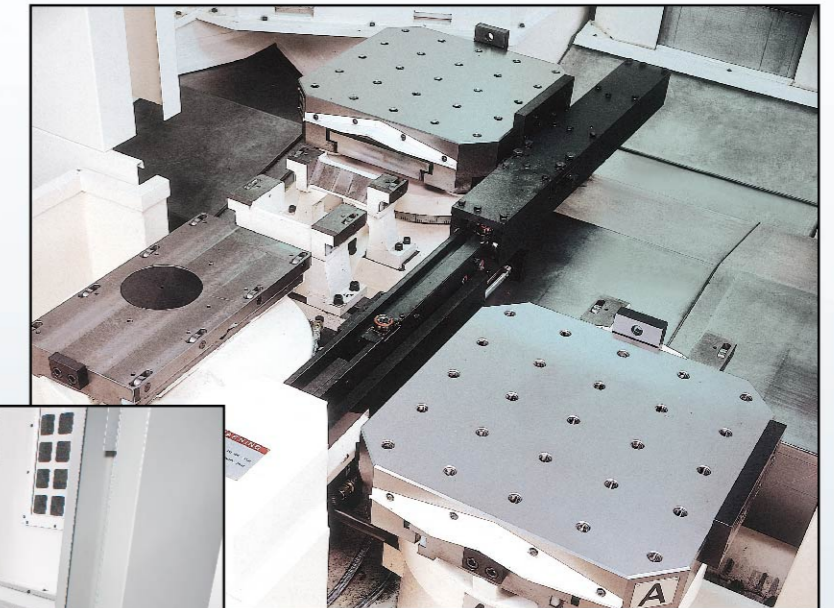

SPINDLE OUTPUT AND TORQUE

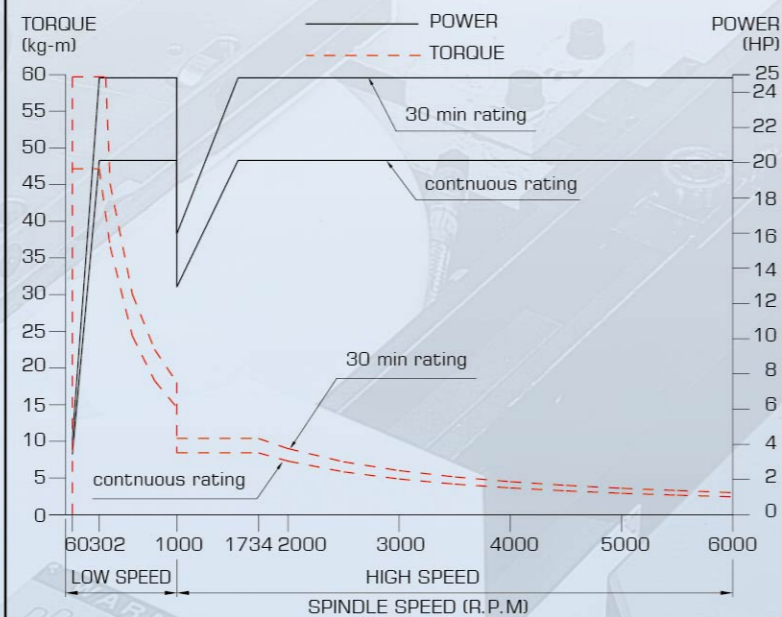

WORKPIECE MAX. DIMENSION

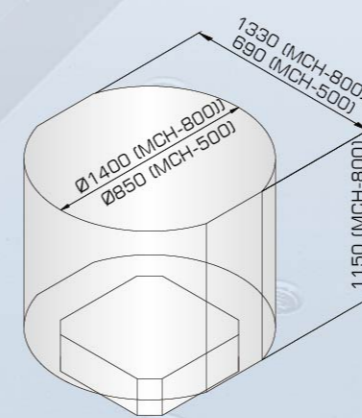

PALLET SIZE

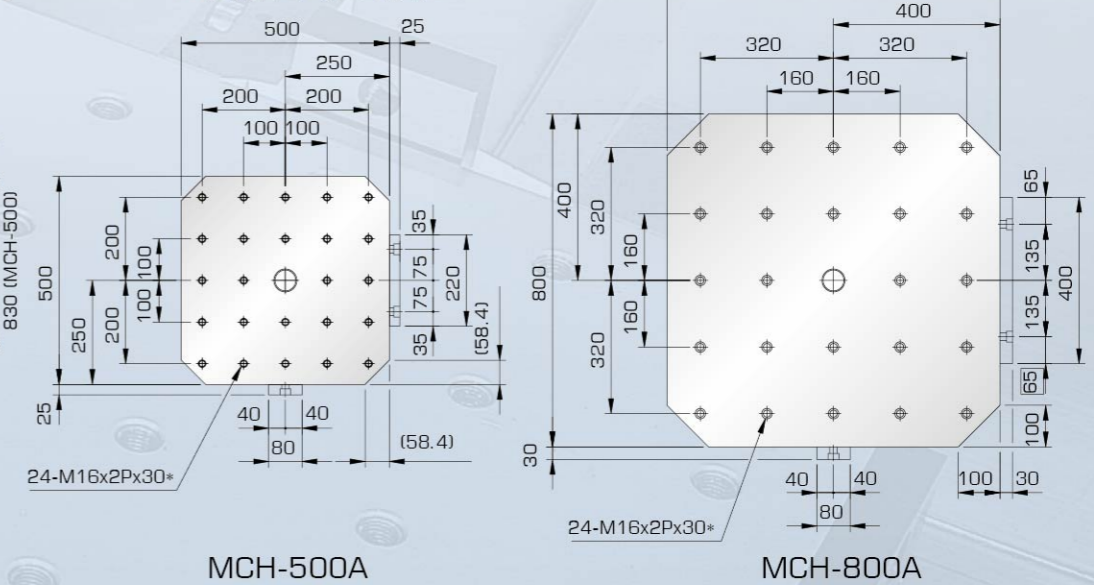

Driven by a hydraulic system with a powerful tool holding arm to achieve fast and accurate motions. The tool magazine is run by a bi-direction chain to pick a tool in the shortest distance. Preparing tool position is available to save time.

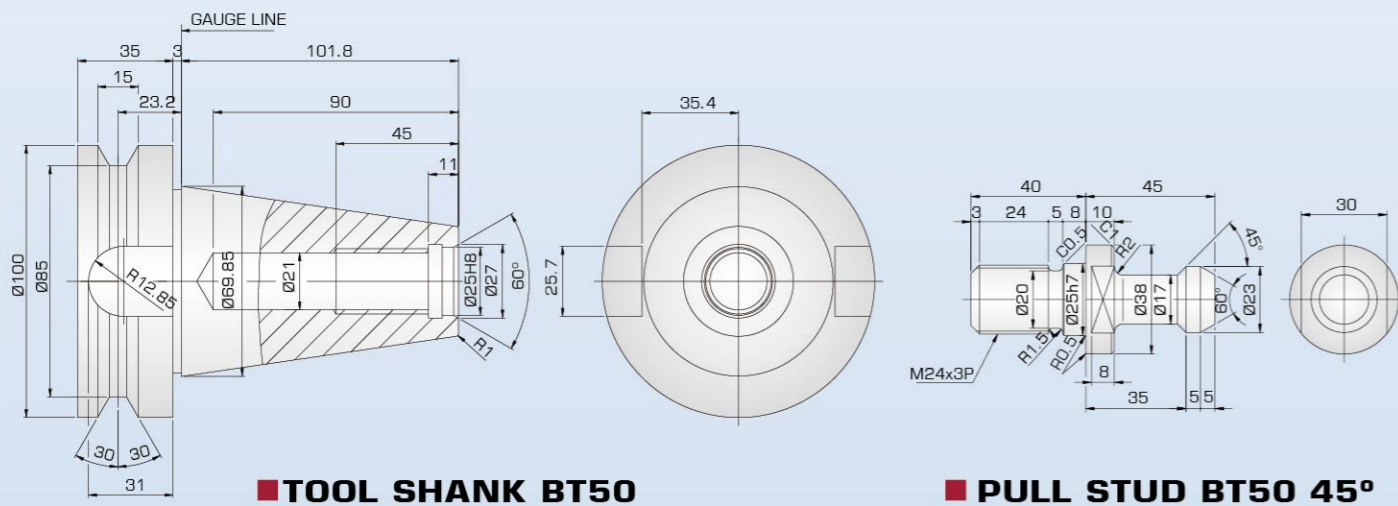
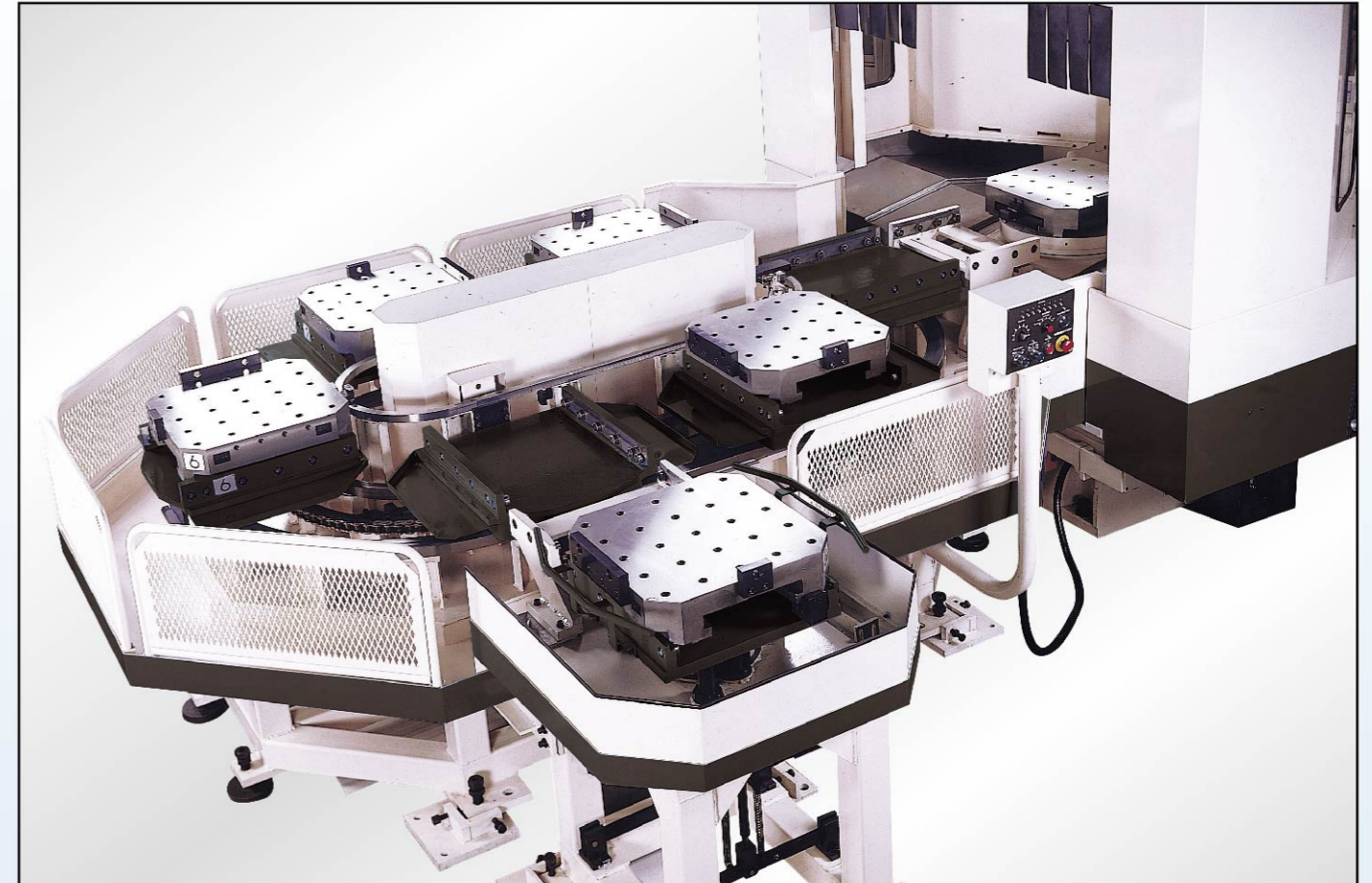
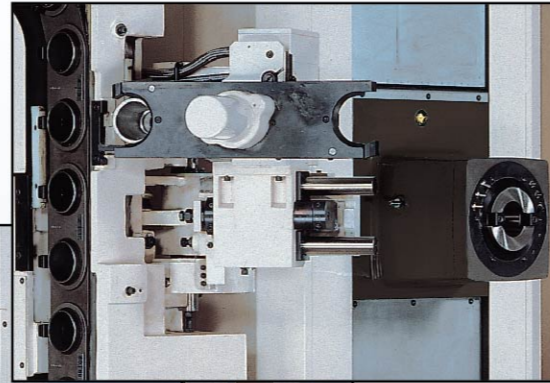
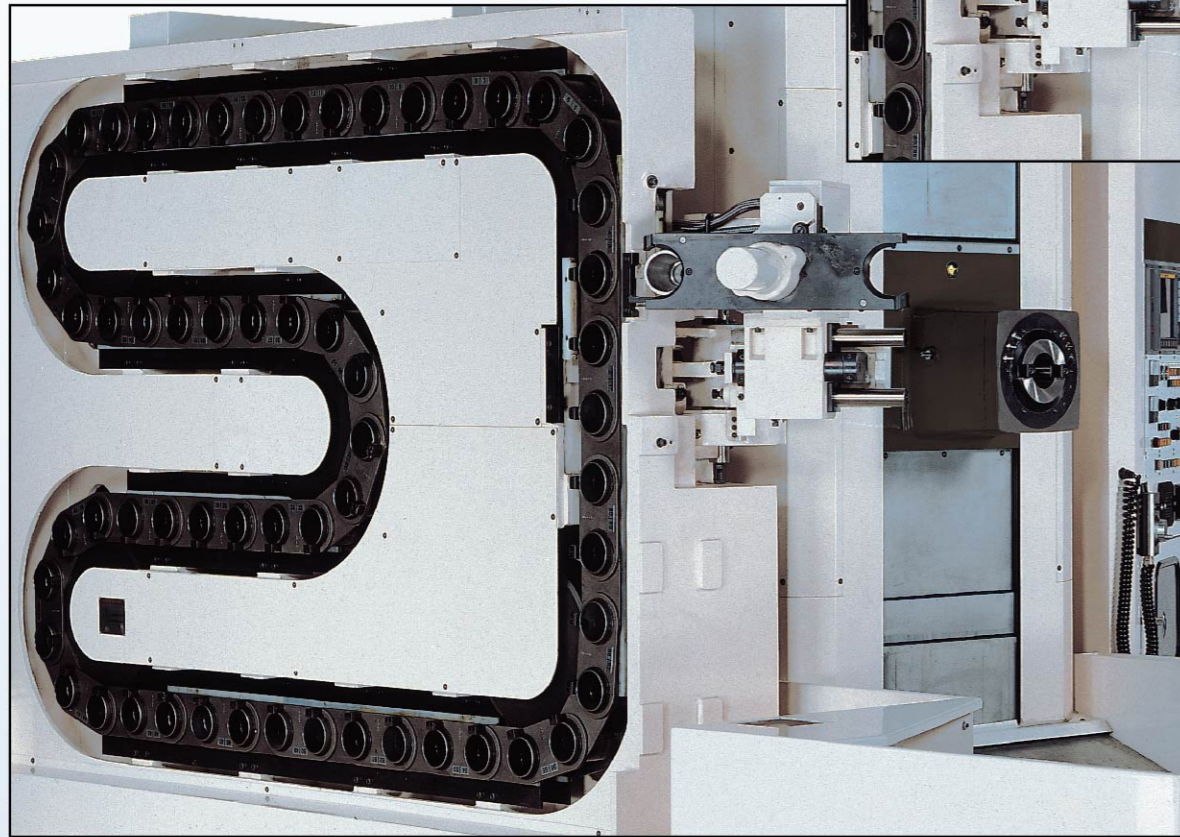

Operator Panel:

Near by spindle with easy and convenient operation. All the operating switches are gathered on the panel and make for easy operations. The removable manual pulse generator makes the setting of workpieces easier and simpler.

QUALITY CONTROL

Each building process—from design, manufacturing to assembling is strictly inspected and tested to guarantee the quality of the products.

- (1) Laser accuracy adjustment.
- (2) 12-sided polygon mirror dividing accuracy adjustment.

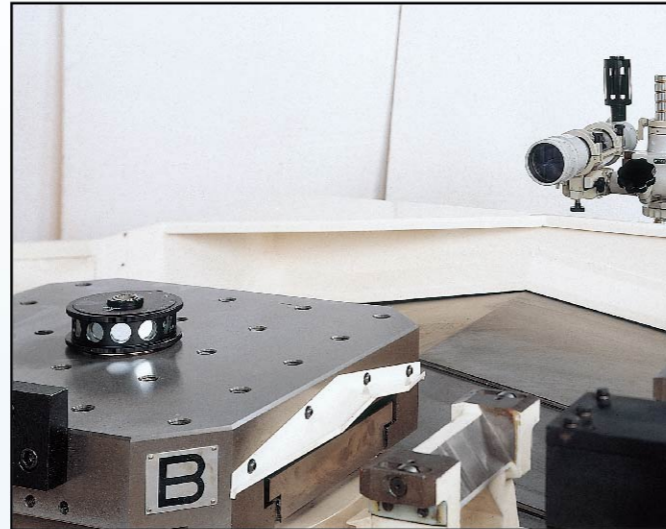

MACHINE DIMENSIONS

■ MCH-500A

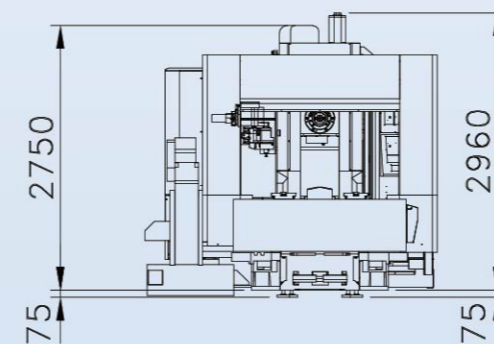
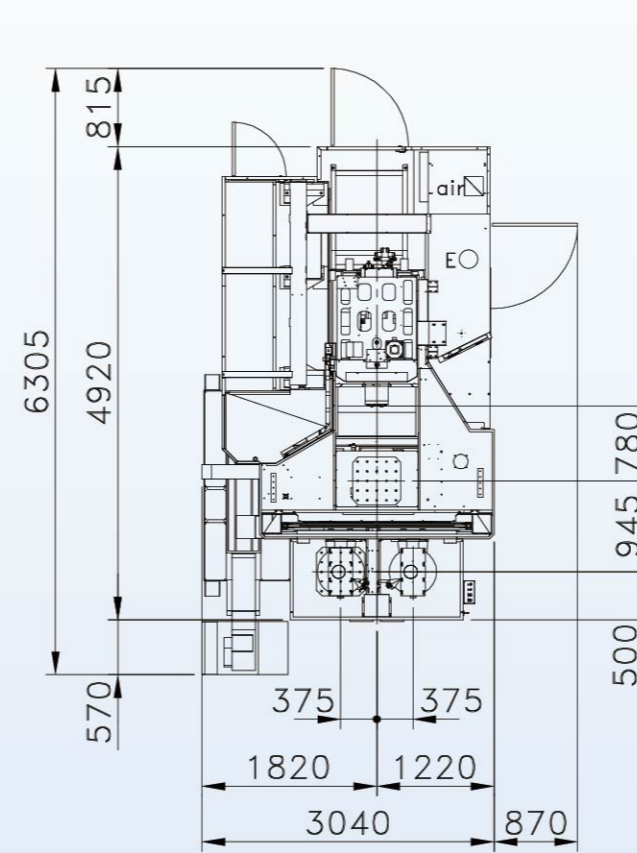

■ MCH-800A

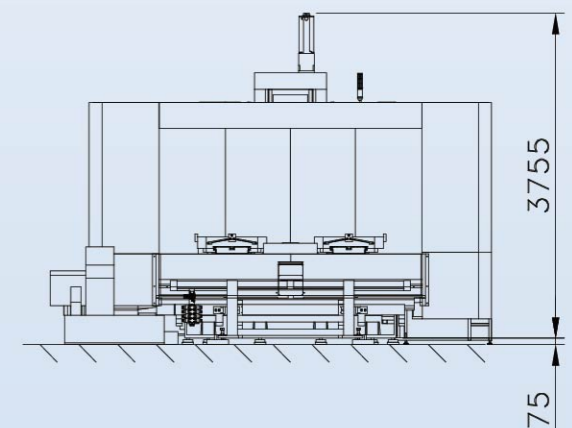
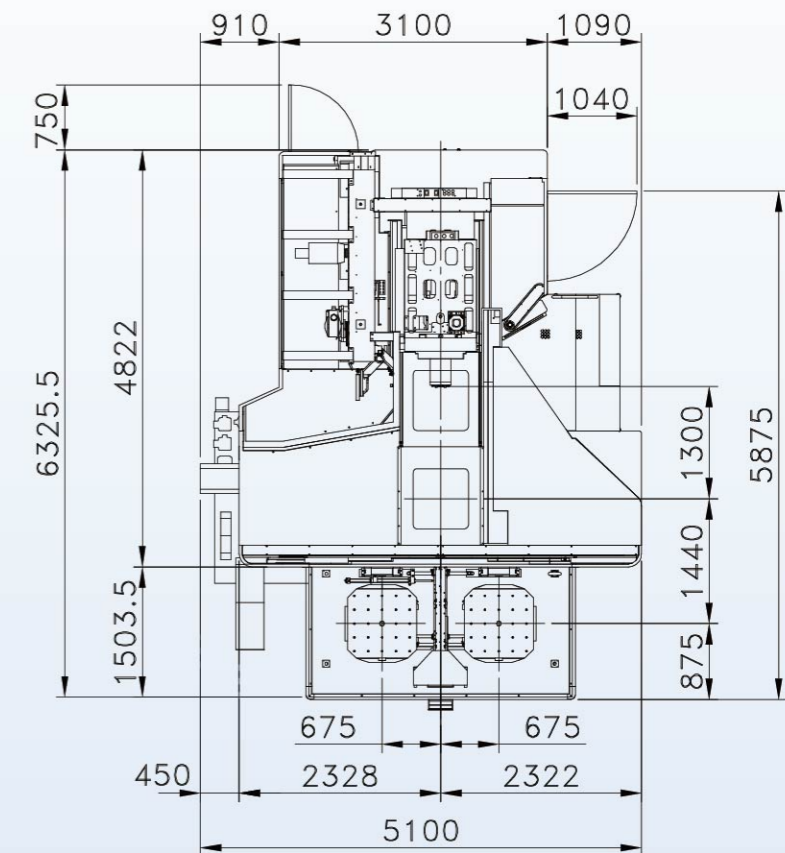

MACHINE SPECIFICATIONS

MODEL	UNIT	MCH-500A		MCH-800A		
TABLE						
Pallet Dimensions	mm (inch)	500 (19.69) x 500 (19.69)		800 (31.50) x 800 (31.50)		
Min. Indexing Angle	°	1° (1/1,000°)		1° (1/1,000°)		
Max. Table Load	kgw (lbs)	800 (1,760)		2,000 (4,400)		
TRAVEL						
Longitudinal Travel (X)	mm (inch)	750 (29.53)		1350 (53.15)		
Vertical Travel (Y)	mm (inch)	680 (26.77)		1000 (39.37)		
Cross Travel (Z)	mm (inch)	600 (23.62)		1100 (43.30)		
Distance of Spindle End to Table Center	mm (inch)	180 (7.09)-780 (30.71)		200 (7.87)-1300 (51.18)		
Distance of Spindle Center to Table Surface	mm (inch)	50 (1.97)-730 (28.74)		50 (1.97)-1,050 (41.34)		
SPINDLE						
Spindle Nose		N.T. 50	N.T. 40	N.T. 50	N.T. 40	
Spindle Speeds	r.p.m.	6,000 (3,500)	10,000 (12,000)	6,000 (3,500)	10,000 (12,000)	
Spindle Speed Range		Two gears variable	Infinite variable	Two gears variable	Infinite variable	
FEED						
Cutting Feed	mm (inch)/min	10,000 (393.70)		10,000 (393.70)		
Rapid Traverse	m (inch)/min	15 (590.55)		18 (708.66)		
Min. Input Increment	mm (inch)	0.001 (0.0001)		0.001 (0.0001)		
ATC (Automatic Tool Changer)						
Tool Holder		BT 50	BT 40	BT 50	BT 40	
Tool Storage Capacity	tools	60 (90, 120)		60 (90, 120)		
Max. Tool Dia. x Length	∅ x mm	110 x 500	110 x 400	110 x 500	110 x 400	
	∅ x inch	4.33 x 19.69	4.33 x 15.75	4.33 x 19.69	4.33 x 15.75	
Max. Tool Weight	kgw (lbs)	20 (44)	8 (17.6)	20 (44)	8 (17.6)	
Tool Selection		Bi - Directional		Bi - Directional		
MOTORS						
Spindle Motor	Continuous Rating	kw / HP	15 / 20.1	7.5 / 10	15 / 20.1	7.5 / 10
	Rated Output for 30 Minutes	kw / HP	18.5 / 24.8	4.0 / 5.4	18.5 / 24.8	11 / 14.7
Drive Motors	X Axis	kw / HP (Torque)	4.0 / 5.4 (22Nm)		3.0 / 4.0 (27Nm)	
	Y Axis	kw / HP (Torque)	4.0 / 5.4 (22Nm)		3.0 / 4.0 (27Nm)	
	Z Axis	kw / HP (Torque)	4.0 / 5.4 (22Nm)		3.0 / 4.0 (27Nm)	
MACHINE WEIGHT SPACE AND PACKING						
Floor Space	mm (inch)	3,170 (124.80) x 4,920 (193.70)		5,110 (201.18) x 7,200 (283.46)		
Net Weight	kgw (lbs)	15,000 (33,000)		25,000 (55,000)		

STANDARD ACCESSORIES:

- Spindle cooling device
- Heat exchanger
- Automatic pallet changer with manual rotation
- Removable-type manual pulse generator
- X.Y.Z linear scales
- Flood coolant device
- Coolant tank
- Spiral type chip conveyors
- Spindle load meter
- Spindle speed meter
- Automatic power cut-off device
- Call light
- Work light
- Tool kit

OPTION ACCESSORIES:

- ATC tool storage: 90, 120
- Coolant system: shower coolant, coolant gun, oil hole coolant.
- Oil mist device
- Flat-type chip conveyor
- Chip wagon
- Automatic centering device
- Tool breakage detection device
- Tool length measuring device
- Tool presenter
- Additional call light
- Buzzer device

■ Design and specifications are subject to change without prior notice.